

4

3

2

1

B

B

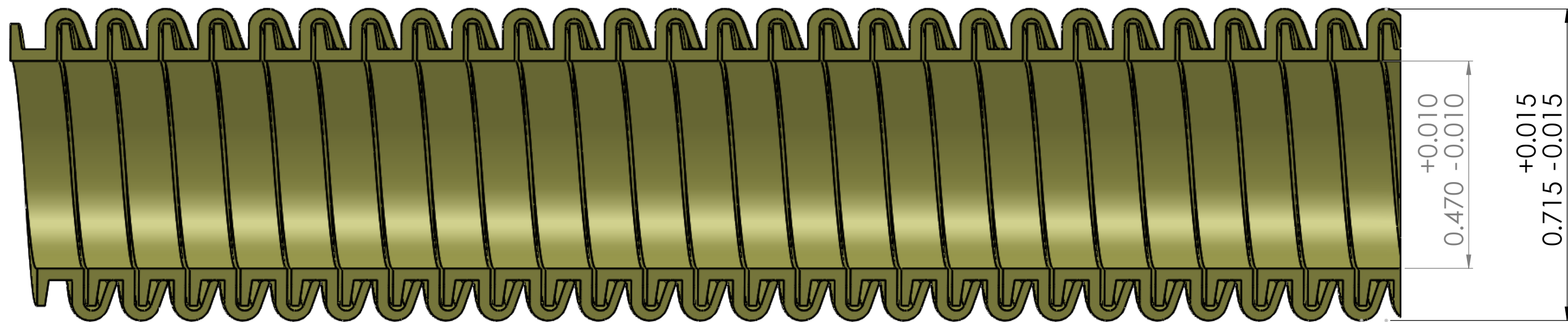

O.D. **.715"(+/- .015")**
18.16mm(+/- .381mm)

I.D. **.470"(+/- .010")**
11.94mm(+/- .25mm)

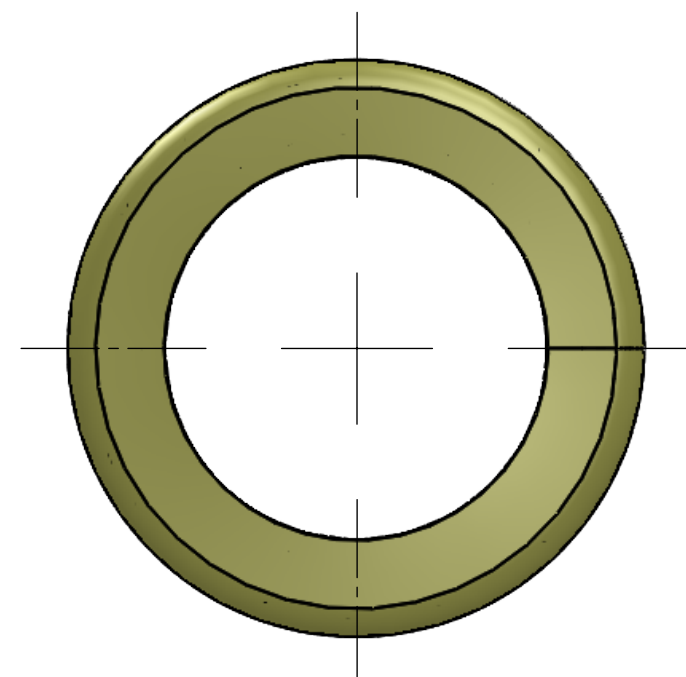

MATERIAL: *Ethyl Vinyl Acetate (EVA)*

Hose Construction	Single profile	UNLESS OTHERWISE SPECIFIED: DIMENSIONS ARE IN INCHES TOLERANCES: FRACTIONAL ANGULAR: MACH BEND TWO PLACE DECIMAL THREE PLACE DECIMAL	NAME	DATE	AMFLEX PLASTICS INC TITLE: 5PR050 SIZE DWG. NO. REV B 5PR050 WEIGHT: SHEET 1 OF 1	
Material	Co-Polymer Blend		DRAWN	Alejo		1/25/21
Bend Radius	1"		CHECKED			
Temp Range	(-40° - 180°)		ENG APPR.			
		INTERPRET GEOMETRIC TOLERANCING PER:	MFG APPR.			
		MATERIAL	Q.A.			
NEXT ASSY	USED ON	FINISH	COMMENTS:			
APPLICATION		DO NOT SCALE DRAWING				

PROPRIETARY AND CONFIDENTIAL
THE INFORMATION CONTAINED IN THIS DRAWING IS THE SOLE PROPERTY OF AMFLEX PLASTICS. ANY REPRODUCTION IN PART OR AS A WHOLE WITHOUT THE WRITTEN PERMISSION OF AMFLEX PLASTICS IS PROHIBITED.

2

1

A

A